



CESSNA CARAVAN



**Cessna**  
A Textron Company

## MORE VERSATILE THAN A SWISS KNIFE

In business as in life, few things can be held to certainty. The ability to ride prevailing winds can make or break your success. To this endeavor, the Cessna Caravan line can provide a powerful constant in a world of variables.

The dispatch reliability of the Caravan models is unparalleled: a remarkable 99%+ rate. For more than 25 years, operators have relied on these aircraft to meet the most demanding mission parameters; they haven't flinched yet. Considering the powerful PT6A-114A turbine powerplant underneath the cowling, it's easy to understand why. This ultra-dependable, 675-horsepower engine from Pratt & Whitney Canada endows each Caravan model with exceptional payload capabilities. Factor in the inherent versatility, configurability and sheer ruggedness of the Caravan line, and the applications become virtually limitless.





Caravan interiors can be easily adapted to maximize seating capacity, cargo space or an ideal combination of both. Rear double doors facilitate loading and unloading, and can be replaced with an electric roll-up door that can be opened in-flight for airdrops or parachute operations. However, such actions are not always necessary for delivering payloads to remote or unusual destinations; the rugged construction of Caravan models allows the accessing of short, unimproved airstrips. Furthermore, the Caravan can be outfitted with amphibious floats or skis should your destinations lack any runway at all.

The interiors can also be customized for executive travel and airline operations—two increasingly popular Caravan applications. With a cavernous cabin and operating costs that are significantly more economical than those of twin-engine turboprop aircraft, Caravans have become an invaluable asset for businesses and operators servicing short- and mid-range destinations around the world.

Yet for all the diverse applications, one principle underscores every Caravan model and application: safety. The high-wing design of the Caravan provides the stability and predictable handling qualities for which Cessna propeller aircraft have long been renowned. And as all Caravan models now operate through the fully integrated G1000 advanced avionics suite, the safety margins for pilot, passengers and payload have never been greater.



## BUSINESS AND CORPORATE

Don't let the rugged looks fool you. Both the Caravan and Grand Caravan can be tailored to attain an elegant and luxurious aesthetic befitting executive travel. The Oasis interior upgrade gives you the style and functionality to transform your Caravan into a high-flying office suite. It can be transitioned to the ideal seating configuration for the mission at hand, and outfitted with everything from finely appointed cabinetry and top-grain leather upholstery to easily accessible work spaces and flat-panel video displays.

Caravan models also boast another claim to comfort few, if any, can match: exceptional headroom. The square-shaped cabin cross section opens up shoulder and head room and, coupled with the aircraft's large windows; it's one of the most airy passenger compartments to be found in the market today.

Of course, the inherent advantages of the Caravan line extend past comfort and style; their renowned reliability ensures you're never left sitting on the tarmac or scurrying to reschedule. This dependability also translates to low maintenance costs. After all, business is business. And with what you will save in fuel consumption and operating costs versus a twin-engine alternative, your business can maintain maximum efficiency without sacrificing performance and opportunity.





## AIRLINE

Proven reliability and low operating costs have made the Caravan line the logical choice for airline operators serving low-volume routes or traveling to remote destinations. Their rugged construction and performance capabilities enable dependable transportation to underdeveloped areas, including those accessible only by waterway.

Every Caravan in the line can be easily configured for executive seating, high density occupancy or to accommodate a group of passengers with oversized cargo. And while the Caravan and Grand Caravan can seat up to eight and twelve passengers respectively, what is most impressive is what they can do with just four: turn a profit. Plus, seats may be installed and removed quickly and easily, enabling operators to fly passengers by day and cargo by night, further enhancing the Caravan's revenue-generating potential. They are easy on fuel consumption, and low-cost to maintain. Flight schedules stay true to the minute, giving passengers the value they need to stay true to your airline.





## AMPHIBIOUS

The Caravan Amphibian releases you from the tether of conventional airstrips, giving you the freedom to travel the planet on your own terms. This dependable workhorse can be an invaluable asset in all walks of life, from personal vacations and outdoor getaways to a diverse range of business and special mission applications.

With a 1,500-lb payload, the Amphibian can fly for more than 300 nautical miles at speeds in excess of 150 knots. Such assured performance has proved to be quite profitable for commercial airline operations that rely on the Amphibian for service to remote and exotic destinations. Like all Caravan models, the Amphibian is both easy and low-cost to maintain, and is far more fuel-efficient than other similarly sized, commercially flown aircraft.

As the Amphibian is the largest single-engine amphibious aircraft on the market, it can be a tremendous resource to special missions that require water access. Whether transporting personnel or hauling cargo, it can handle the job and then some. In addition to its voluminous and configurable cabin, the large, sturdy floats of the Amphibian can also be loaded with supplies or cargo in watertight storage compartments.

Of course, nothing beats loading an aircraft with recreational gear, family and friends. Forget the winding roads, the bad food and rest room stops; the Amphibian is your secret expressway—an escape to your own personal oasis where the masses cannot follow.





The World On Time

FedEx  
Feeder  
N800FE

## CARGO HAULING

All Caravan models boast exceptional payloads, and can be configured both inside and out to mesh with the specific parameters of a freight-hauling mission. Yet one model is specifically designed to this purpose: the Super Cargomaster. With 452 cubic feet of total cargo volume, the Cargomaster can accommodate even the largest orders, including fully palletized shipments. Its 49 x 50-inch double cargo doors facilitate fast and easy loading, and its flat floor and square cabin cross section allow for highly efficient use of its ample space.

But it is on the performance front where the Cargomaster truly earns its reputation, and, in many instances, its insignia. The Cargomaster plays a critical role in the everyday operations of the world's leading freight and delivery service. Indeed, FedEx employs more than 250 Cargomasters within its worldwide fleet. With a 99%+ dispatch reliability rate, it's easy to see why; both deliver on the promise of "when it absolutely positively has to be there." And the reliable performance of the 675-horsepower Pratt & Whitney Canada turboprop ensures "it" always is. Loaded front-to-back, the Cargomaster can haul more than 2,500 pounds of cargo a distance of 400 nautical miles in less than three hours time.

As FedEx delivers parcels to locations around the world, the ability to maintain and service their aircraft in faraway locations is vital to upholding their customer promise. Cessna fulfills this need. Our worldwide network of service stations provides the exceptional service and support that keeps Caravans everywhere running smoothly, reliably and on schedule.



## SPECIAL MISSIONS

In the context of special mission operations, there's a sense of rightness to a Cessna Caravan: a confidence that comes with knowing you have availed yourself of the best possible resource for the job. The rugged construction of all Caravan models is reassuring in itself. And with the versatility and configurability to meet the ever-shifting parameters of a diverse array of special missions, the Caravan line is your rock-solid star performer—not afraid to get dirty, always ready for the field.



28

PERMITS REQUIRED FOR ALL  
OPERATIONS IN THIS AREA

PERMITS REQUIRED FOR ALL  
OPERATIONS IN THIS AREA

## MEDIVAC

Medivac missions rarely have an extra margin for time, which is why the Cessna Caravan and Grand Caravan have long been the preferred choices for air ambulance services. They have the proven reliability that medical service providers can count on to deliver, even in adverse conditions. Both can accommodate large support staffs, and can be configured for specialized loading systems that minimize ground time. Furthermore, they can both access short and unimproved airstrips, an invaluable benefit for pick-ups in rural or remote areas.



## INTELLIGENCE, SURVEILLANCE AND RECONNAISSANCE

Several features make Caravan models ideal for keeping tabs on the ground. Their high-wing design provides excellent ground visibility, while slow and low flight characteristics allow for quiet, secure and controllable positioning in the sky. They can be outfitted with sophisticated equipment such as video, still photography and infrared camera systems. And, with their fuel efficiency and low operating costs, your crew can remain aloft and on guard for longer periods of time.



## SEARCH & RESCUE

The high-wing design and large windows of Caravan aircraft permit a 360° view of the ground below, while endowing you with stable slow-speed and low-altitude flying characteristics that permit a thorough sweep of your search grid. They are reliable, and possess the size and configurability needed for seamless integration of specialized equipment, while still enabling you to carry a larger crew. Their fuel efficiency and ample range allow for longer time on station, and their ability to access short or unpaved airstrips can be invaluable to rescue operations.



## PARACHUTE OPERATIONS

The reliability and durability of Cessna Caravan models have been proven through countless parachute operations. The single turbine engine gives them great performance-on-station time, and makes them significantly more economical than twin-engine alternatives. The standard cargo doors can be removed or replaced with a Cessna-designed electric roll-up door that can be opened in flight. Furthermore, the high-wing design allows for an obstruction-free jump zone and keeps the aircraft steady and stable during low-speed operation. And as Caravans can access short, unimproved airstrips, they are used for military-based aerial deployments in countries around the world.



## AERIAL MAPPING/PHOTOGRAPHY

Long-range capable, low-cost to maintain, and fuel-efficient, Cessna Caravans make the most of each mission. Their high-wing design allows for superior visibility and a smooth, stable shooting platform. They can be easily configured to accommodate both an expanded crew and the specialized equipment needed for photographic and cartographic excursions, such as floor-mounted cameras, video and still photography systems. Cessna can assist in locating aftermarket options your mission might require.



## GEOPHYSICAL EXPLORATION

Whether the mission is the speedy delivery of specialized parts or critical personnel, the Cessna Caravan and Grand Caravan give you the full package of performance and reliability to keep your project sites running at optimal efficiency. They can easily access the short, unimproved airstrips that are oftentimes in far closer proximity to exploratory sites than commercial options. They can be configured for maximum cargo space, seating or an ideal combination of both. Their high-wing design affords great stability at any speed, so your cargo is always secure, even in hot, turbulent air above open plains.



# WORLDWIDE SERVICE AND SUPPORT

No matter where you fly, your Caravan is always close to home. Our worldwide network of service stations can provide you with exceptional service and support to ensure the maximum uptime for your aircraft, and the utmost safety for its occupants.

With satellite locations around the world, Cessna Service Parts & Programs (CSP&P) ensures even the most pressing parts demands are met with minimal AOG time. Whether the order is for a 1935 C-34 or a new Caravan Amphibian, Cessna Parts Distribution doesn't rest until the right part is in the safe hands of one of our knowledgeable service and repair experts.

And no matter your need, one easy point of contact puts you in touch with a Cessna expert who can deliver: simply call 1-800-4-CESSNA, +1-316-517-6056 or go to [Cessna.com](https://www.cessna.com). Wherever you are, you'll always find us standing ready to serve you.



SHANDONG AIRLINES  
N1284F

山东航空公司

# AVIONICS

**GARMIN G1000** Adapted specifically for Cessna, the all-glass Garmin G1000 avionics suite with available Synthetic Vision Technology (SVT) integrates all primary flight, engine and sensor data to provide intuitive, at-a-glance situational awareness. Real-time, flight-critical data is gathered and displayed on three configurable, large-format high-resolution screens, reducing the clutter found on so many aircraft.

One of the most amazing capabilities of the Garmin G1000 is the GFC 700 autopilot. Once programmed and engaged, the GFC 700 is capable of performing virtually all of the necessary pilot actions between climb out and final descent. It provides in-flight support features such as automated Go Around and Course Reversal features. With precise vertical and horizontal guidance, the GFC 700 puts you right on the nose of your approach every time, and can even schedule airspeeds for both climbs and descents. And as it comes standard with every new Cessna ranging from the Skyhawk SP to the Citation Mustang, transitioning to a Caravan model from a smaller Cessna single-engine aircraft is that much smoother and more intuitive.



## G1000: FEATURES\*

\*Simulated flight information



These magenta rectangular pathways provide a visual window to help pilots follow the intended flight route. Spaced no more than 1,000 meters apart, they have guidelines in each corner that point in the direction of the active flight plan leg.



Using Synthetic Vision Technology (SVT), the Towers and Obstacles database makes awareness of non-terrain structural hazards crystal clear, even in low visibility.

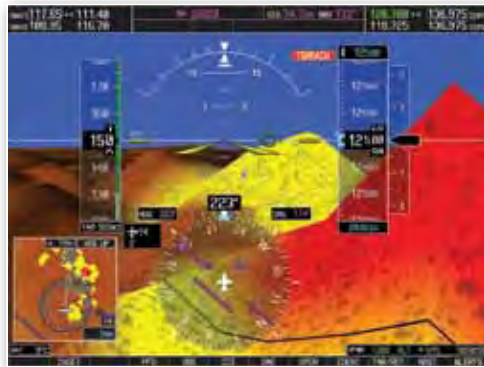

The topographical display provides excellent situational awareness over all kinds of terrain. The color-specific overlays clearly indicate potential terrain conflict areas.



Moving traffic is easy to spot in this three-dimensional format. Using familiar TAS symbology, SVT shows the altitude of other traffic in the area. As other aircraft get closer, their symbols grow larger.

## POWERPLANT

Such robust capabilities demand reliable engine performance, and the Pratt & Whitney Canada PT6A-114A delivers. With over 18 million total flight hours logged, this 675-horsepower turbine powerplant has a scheduled overhaul interval of 3,600 hours and a hot section inspection at 1,800 hours. Both engine and accessories are easily accessible for maintenance, as the cowling can be completely removed in less than 15 minutes.



## LANDING GEAR

The landing gear of Cessna Caravan models is made to withstand the rigors of rough and unimproved airstrips. The main gear is a massive steel tube linked directly to the fuselage. And the nose gear is engineered to absorb both vertical and lateral force by transmitting the impact to the fuselage. Its large, rough-field tires can be set down on grass, gravel or even the most rudimentary of runways.



## LARGE CARGO DOOR

The Caravan's left-side, 49 x 50-inch double cargo door allows easy, precise insertion of palletized cargo and other large items. The sturdy two-piece design provides for maximum clearance and convenient access for loaders.



## CARGO POD

Available on all models except the Amphibian, the cargo pod is one of the Caravan's most popular options. It provides an additional 111 cubic feet and over 1,000 pounds of useful storage space, loadable through four separate areas to prevent weight shifting. Its wide loading doors facilitate easy access.





Even with TKS ice protection, one should always take immediate steps to exit an icing condition when encountered.

## FIKI CERTIFIED – TKS ICE PROTECTION

FIKI Certification makes the most reliable aircraft in aviation even more reliable. The Cessna Caravan is now TKS Ice Protection Certified. The model of dispatch reliability in general aviation, the Caravan can be fortified for operation within a known icing environment, should such conditions be encountered.

No ice protection system provides the same level of protection as the proven TKS weeping wing system. This lightweight system can provide up to 3 1/2 hours of complete protection to the airframe of your Caravan, with virtually no tax to its performance. Should you encounter icing conditions, you're protected with the simple push of a button. You and your payload reach your destination safely and on-schedule.

- Complete airframe protection for up to 3 1/2 hours— wings, tail surfaces, propeller and windshield
- Increased dispatch reliability
- Virtually no performance penalty
- Easy ON/OFF operation
- Low maintenance
- Lightweight



## EASE OF USE

Of significant advantage to the pilot is how easy the system is to use while flying the Caravan. Simply turn the system ON when icing is encountered and OFF when leaving icing conditions. No distractions—you stay focused on piloting your Caravan out of icing conditions.

While operating the system, the pilot can choose from four modes: Normal, High, Max Flow and Backup. In Normal mode, a protective film of glycol prevents the formation of ice; in High or Max Flow modes, the glycol chemically breaks the ice bond. The Backup mode is provided as a redundancy capability in the event the normal operation modes are rendered inoperable.

In all modes, the system will eliminate run-back ice.

Once activated, the system can provide up to 3 1/2 hours of ice protection with a full tank of ice protection fluid.



## HOW IT WORKS

Laser drilled titanium panels are installed on the leading edges of the wings, lift struts, and horizontal and vertical stabilizers, while a slinger ring is installed on the propeller, and a spray bar is positioned on the windshield. A glycol-based fluid is exuded through the panels, ring and bar, flowing over these surfaces to keep the aircraft virtually ice-free.

The glycol-based fluid is metered from a tank by two electrically driven pumps through a series of micro-filters to proportioning units. The proportioning units contain calibrated capillary tubes, which apportion fluid to the individual panels and the propeller sling ring.



## LIGHTWEIGHT

The added weight resulting from an installation of the TKS system is minimal. The system weighs 100 pounds without fluid, and approximately 292 pounds with a full tank.



## EASY TO MAINTAIN

Upkeep is minimal. As the system is used, it flushes out any accumulation of debris from the panels. Glycol, the main ingredient of the ice protection fluid, has cleaning properties and will not harm the paint finish of the Caravan.



## VIRTUALLY NO LOSS IN PERFORMANCE

The TKS system adds significant anti-ice and de-ice capabilities to the Caravan models, yet there is virtually no loss in performance as a result of the system's installation.



## OASIS INTERIOR OPTIONS

The Oasis interior option for the Caravan, Grand Caravan and Amphibian marries business jet-like comfort and sophistication with the aircraft's rugged and versatile capabilities. Tailor your Caravan with a choice of six distinct floor plans, four distinctive color combinations and an almost infinite selection of options. Designed and executed by Yingling Aviation, the Oasis interior is the perfect blend of precision craftsmanship, refined durability and infinite mission capabilities.

Choose the seat that suits your mission. You now have the choice of two seat types: our VLS seat or the Classic Oasis Executive seat. For those applications that require the ability to quickly and easily install or remove seats to accommodate varied missions, the lightweight VLS seat is easy to manage and durable. If that flexibility isn't a requirement, our Classic Oasis Executive seats deliver full functionality and supreme comfort.

Productivity and comfort: Though specific features vary by floorplan, each Oasis interior incorporates features such as folding tables and a 110-volt power outlet. The Classic Oasis Executive seats offer 360-degree swivel to facilitate in-flight collaboration.

Proven added value: As the only Cessna-approved interior upgrade for the Caravan line, the Oasis interior package is recognized by Vref Aircraft Value Reference and Aircraft Blue Book Digest as increasing your aircraft's value at resale. Talk to your Cessna representative for complete information on all of the features and options available and turn your Caravan into an Oasis in the sky.



## INTERIOR CONFIGURATIONS

### Executive

The executive seating options take you to extreme places in extreme comfort.

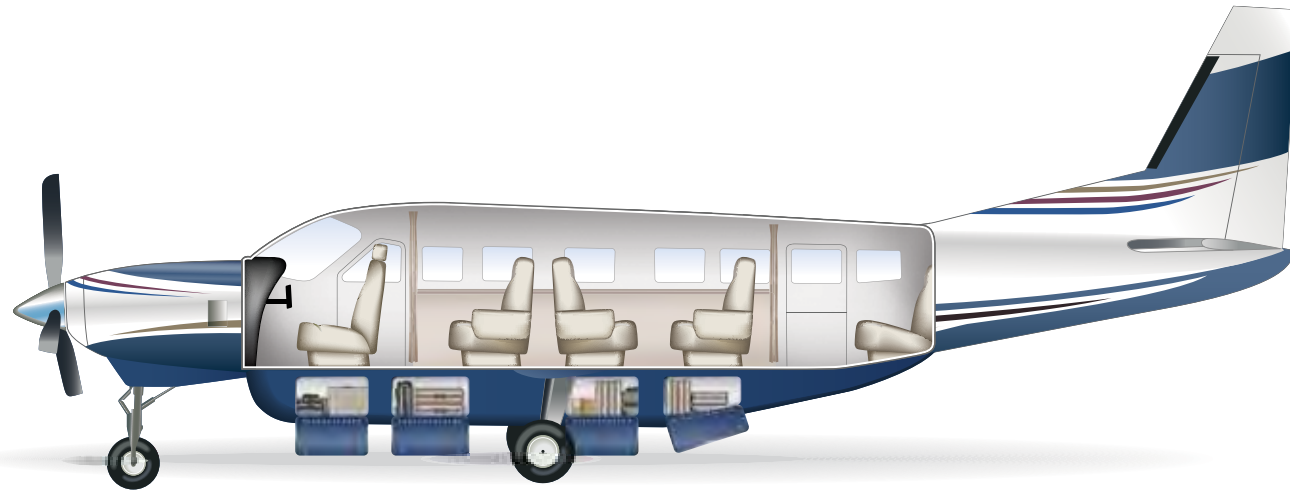

### Airline

Flexible seating configurations provide for up to 12 passengers and two pilots.\*

#### Single-Seat Rows



#### High-Density Airline



\*depending on local regulations.





**Combination**

Passengers and cargo? No problem. Your Caravan can adapt to handle the load.



**Cargo**

The Super Cargomaster offers a rugged, flat floor and 400 pounds more payload.



# SPECIFICATIONS

## CARAVAN 675

### Caravan 675

#### AIRCRAFT DIMENSIONS

Overall Height	14 ft 10 in (4.5 m)
Overall Length	37 ft 7 in (11.5 m)
Wingspan	52 ft 1 in (15.9 m)

#### CABIN DIMENSIONS

Height	54 in (1.4 m)
Length	17 ft 4 in (5.3 m)
Width	64 in (1.6 m)
Maximum Seating Capacity	14*
Baggage Capacity	325 lb (147 kg)

#### DESIGN WEIGHTS & CAPABILITIES

Maximum Ramp Weight	8,035 lb (3,645 kg)
Maximum Takeoff Weight	8,000 lb (3,629 kg)
Typically Equipped Empty Weight	4,751 lb (2,155 kg)
Maximum Useful Load	3,284 lb (1,490 kg)
Usable Fuel Capacity	2,224 lb (1,008 kg) 332 gal (1,257 l)

#### PERFORMANCE

Maximum Cruise Speed	186 ktas (344 km/hr)
Range (45-min reserve, max cruise, 10,000 ft)	946 nm (1,752 km)
Rate of Climb at Sea Level	1,234 ft/min (376 m/min)
Certified Ceiling	25,000 ft (7,620 m)
Takeoff Distance to 50 ft	2,055 ft (626 m)
Landing Distance (over 50 ft obstacle)	1,625 ft (495 m)

#### POWERPLANT

Engine	PT6A-114A
Horsepower	675 shp
TBO	3,600 hrs
Propeller	McCauley Three-Bladed, Constant Speed, Full Feathering

\*depending on local regulations.

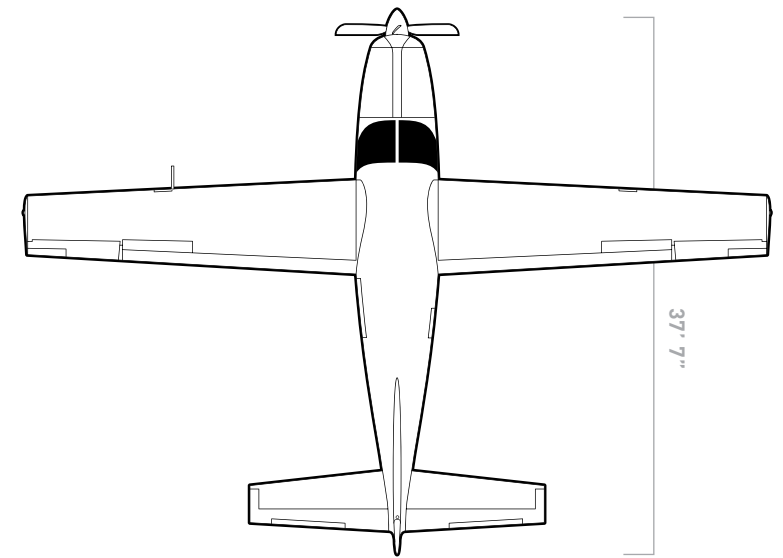

**RANGE AND PAYLOAD**

**PAYLOAD** Caravan (without pod)  
 (lb) BOW = 4,951 lb/2,246 kg  
 (kg) (Includes 200 lb pilot & 45 minute fuel reserve)

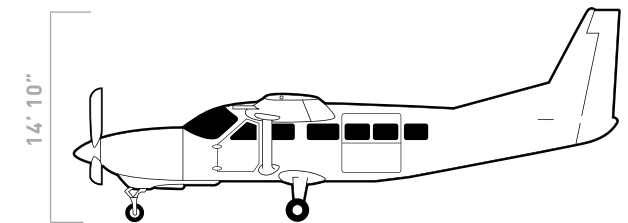
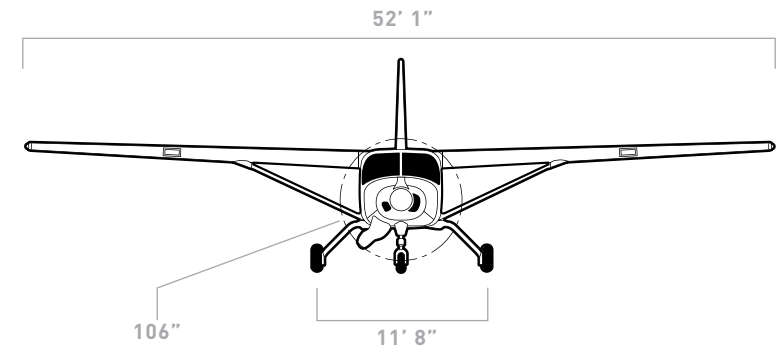
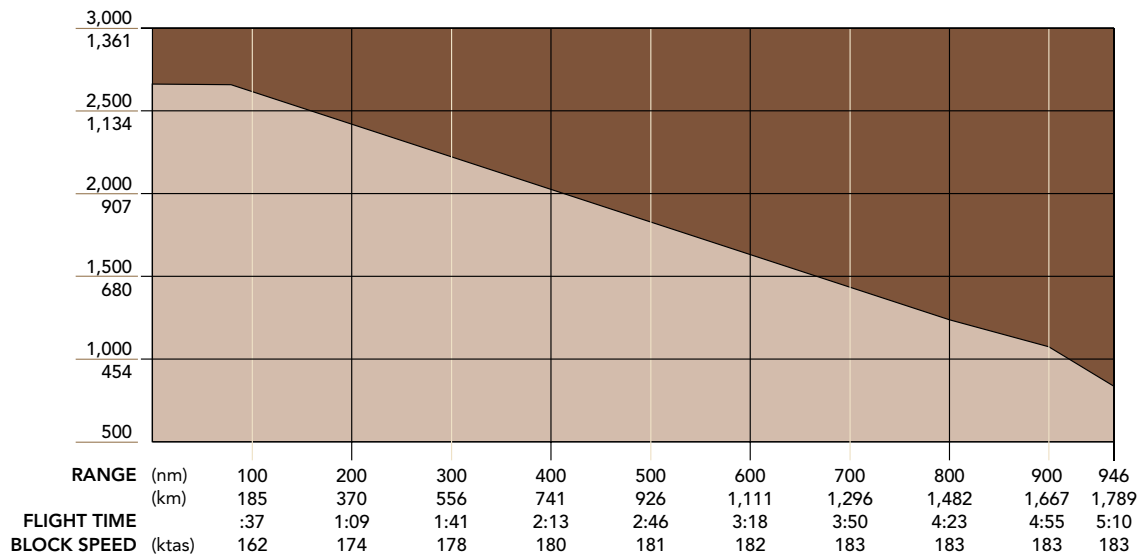

# SPECIFICATIONS GRAND CARAVAN

## Grand Caravan

### AIRCRAFT DIMENSIONS

Overall Height	15 ft 6 in (4.7 m)
Overall Length	41 ft 7 in (12.7 m)
Wingspan	52 ft 1 in (15.88 m)

### CABIN DIMENSIONS

Height	54 in (1.4 m)
Length (bulkhead to bulkhead)	21 ft 4 in (6.5 m)
Width	64 in (1.6 m)
Maximum Seating Capacity	14*
Baggage Capacity	320 lb (145 kg)

### DESIGN WEIGHTS & CAPABILITIES

Maximum Ramp Weight	8,785 lb (3,985 kg)
Maximum Takeoff Weight	8,750 lb (3,969 kg)
Typically Equipped Empty Weight	5,051 lb (2,291 kg)
Maximum Useful Load	3,734 lb (1,694 kg)
Usable Fuel Capacity	2,224 lb (1,008 kg) 332 gal (1,257 l)

### PERFORMANCE

Maximum Cruise Speed	184 kt (341 km/hr)
Range (45-min reserve, max cruise, 10,000 ft)	917 nm (1,698 km)
Rate of Climb at Sea Level	975 ft/min (297 m/min)
Certified Ceiling	25,000 ft (7,620 m)
Takeoff Distance to 50 ft	2,420 ft (738 m)
Landing Distance (over 50 ft obstacle)	1,795 ft (547 m)

### POWERPLANT

Engine	PT6A-114A
Horsepower	675 shp
TBO	3,600 hrs
Propeller	McCauley Three-Bladed, Constant Speed, Full Feathering

\*depending on local regulations.

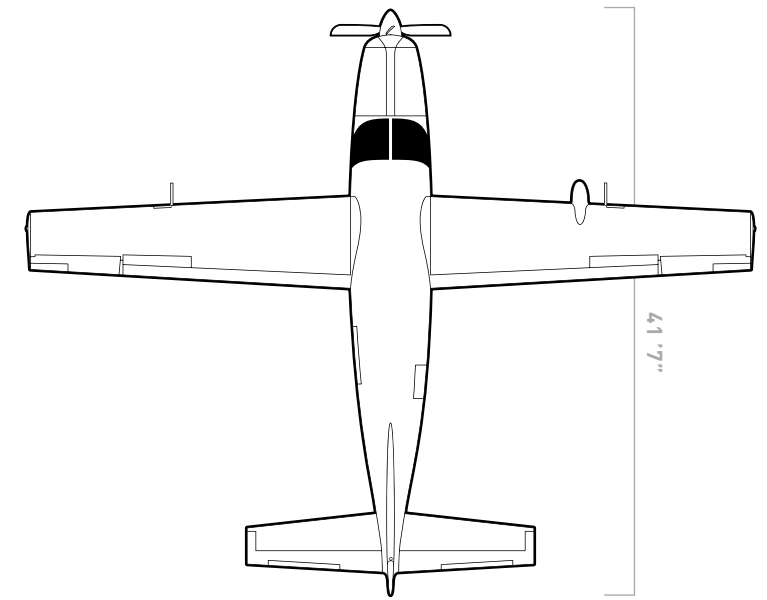

### RANGE AND PAYLOAD

**PAYLOAD** Grand Caravan (with cargo pod)  
 (lb) BOW = 5,431 lb/2,463 kg  
 (kg) (Includes 200 lb pilot & 45 minute fuel reserve)

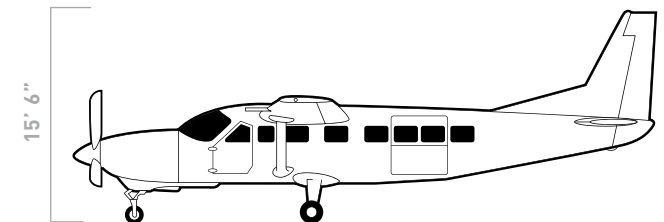
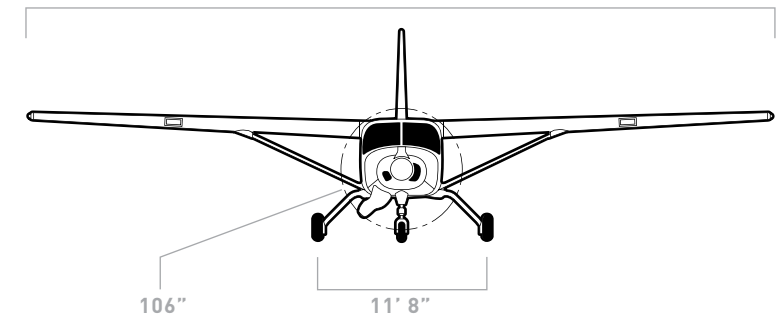
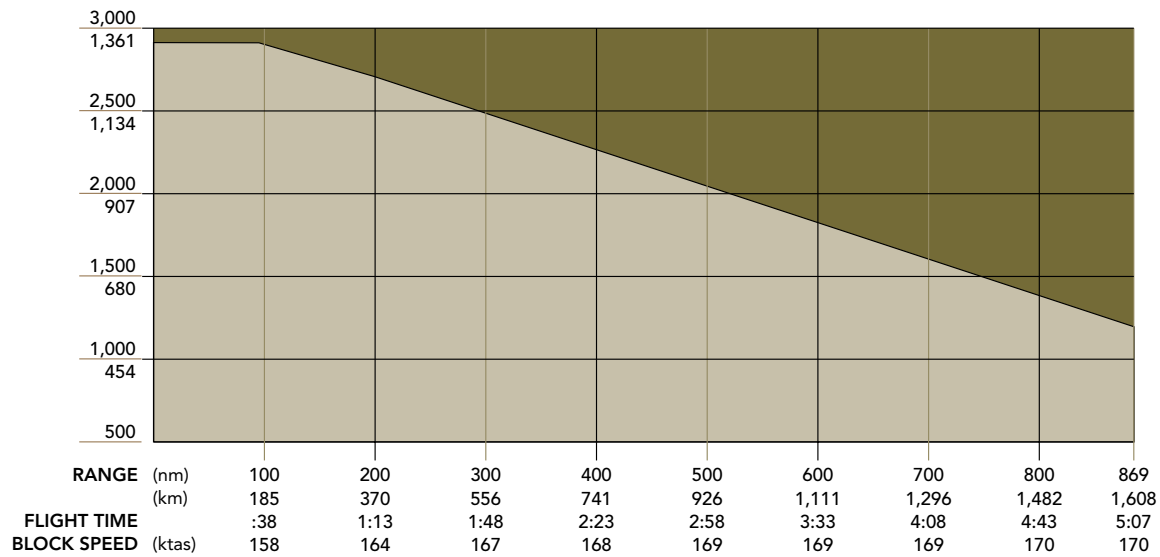

# SPECIFICATIONS CARAVAN AMPHIBIAN

## Caravan Amphibian

### AIRCRAFT DIMENSIONS

Overall Height	16 ft 4 in (4.99 m)
Overall Length	38 ft 11 in (11.9 m)
Wingspan	52 ft 1 in (15.9 m)

### CABIN DIMENSIONS

Height	54 in (1.4 m)
Length (bulkhead to bulkhead)	17 ft 4 in (5.3 m)
Width	64 in (1.6 m)
Maximum Seating Capacity	Crew + 9 Passengers
Baggage Capacity	725 lb (329 kg)

### DESIGN WEIGHTS & CAPABILITIES

Maximum Ramp Weight	8,395 lb (3,808 kg)
Maximum Takeoff Weight	8,360 lb (3,792 kg)
Typically Equipped Empty Weight	5,727 lb (2,598 kg)
Maximum Useful Load	2,668 lb (1,210 kg)
Usable Fuel Capacity	2,224 lb (1,008 kg ) 332 gal (1,257 l)

### PERFORMANCE

Maximum Cruise Speed	165 kt (306 km/h)
Range (45-min reserve, max cruise, 10,000 ft)	820 nm (1,519 km)
Rate of Climb at Sea Level	1,031 ft/min (314 m/min)
Certified Ceiling	20,000 ft (6,096 m)
Takeoff Distance to 50 ft	3,280 ft (1,000 m)
Landing Distance (over 50 ft obstacle)	2,045 ft (623 m)

### POWERPLANT

Engine	PT6A-114A
Horsepower	675 shp
TBO	3,600 hrs
Propeller	McCauley Three-Bladed, Constant Speed, Full Feathering

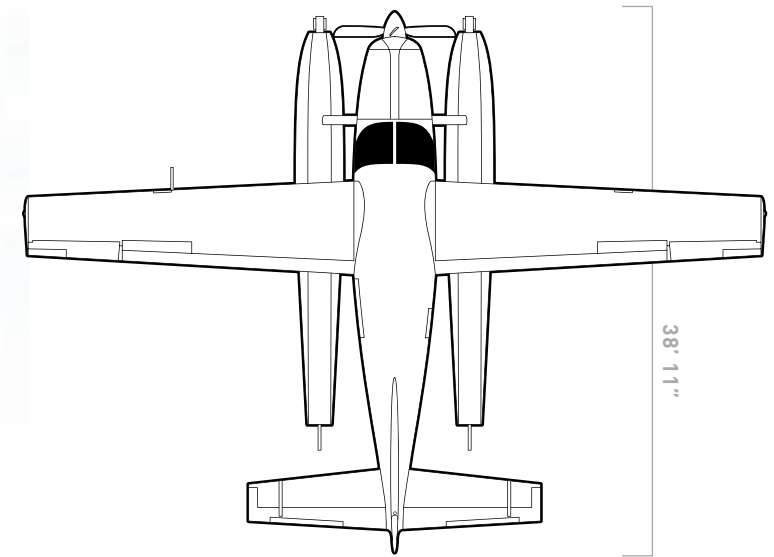

**RANGE AND PAYLOAD**

**PAYLOAD** Caravan Amphibian (without pod)  
 (lb) BOW = 5,927 lb/2,688 kg  
 (kg) (Includes 200 lb pilot & 45 minute fuel reserve)

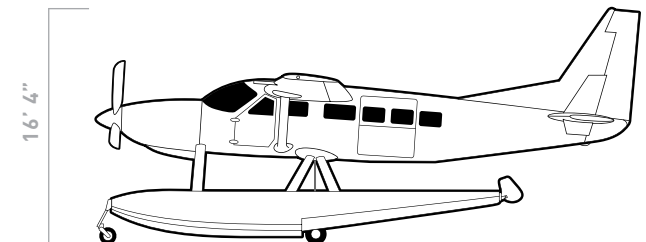
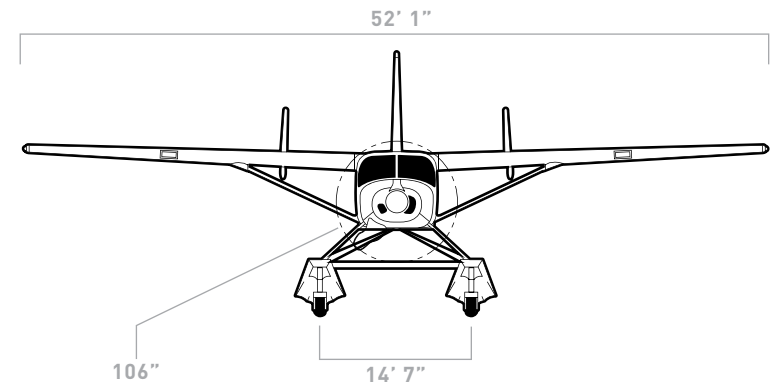
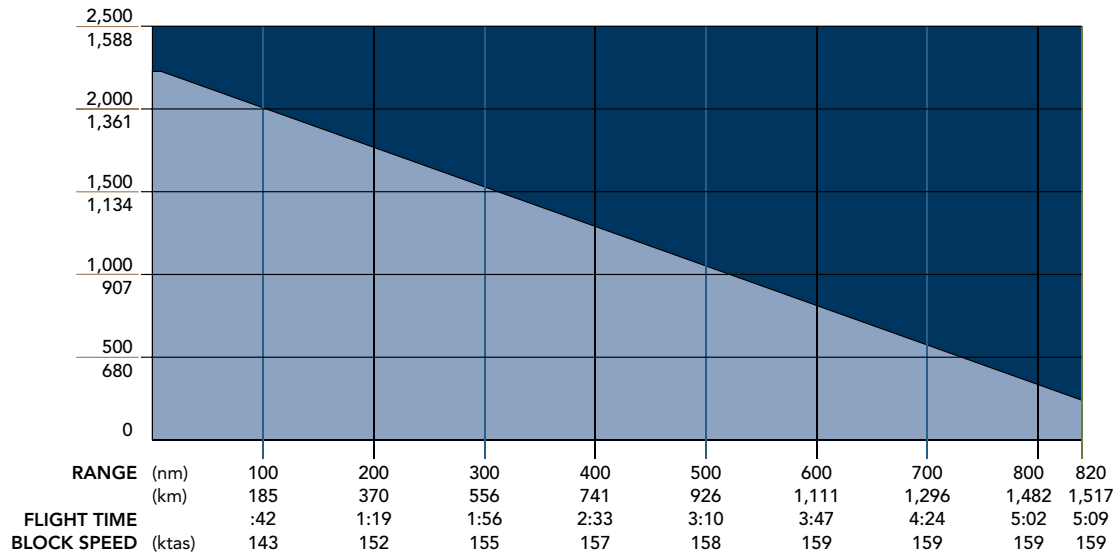

# SPECIFICATIONS SUPER CARGOMASTER

## Super Cargomaster

### AIRCRAFT DIMENSIONS

Overall Height	15 ft 6 in (4.7 m)
Overall Length	41 ft 7 in (12.7 m)
Wingspan	52 ft 1 in (15.9 m)

### CABIN DIMENSIONS

Height	54 in (1.4 m)
Length (bulkhead to bulkhead)	21 ft 4 in (6.5 m)
Width	64 in (1.6 m)
Maximum Seating Capacity	2
Baggage Capacity	3,248 lb (1,473 kg)

### DESIGN WEIGHTS & CAPABILITIES

Maximum Ramp Weight	8,785 lb (3,985 kg)
Maximum Takeoff Weight	8,750 lb (3,969 kg)
Typically Equipped Empty Weight	4,813 lb (2,183 kg)
Maximum Useful Load	3,972 lb (1,802 kg)
Usable Fuel Capacity	2,224 lb (1,008 kg ) 332 gal (1,257 l)

### PERFORMANCE

Maximum Cruise Speed	175 kt (324 km/hr)
Range (45-min reserve, max cruise, 10,000 ft)	869 nm (1,609 km)
Rate of Climb at Sea Level	925 ft/min (282 m/min)
Certified Ceiling	25,000 ft (7,620 m)
Takeoff Distance to 50 ft	2,500 ft (762 m)
Landing Distance (over 50 ft obstacle)	1,740 ft (530 m)

### POWERPLANT

Engine	PT6A-114A
Horsepower	675 shp
TBO	3,600 hrs
Propeller	McCauley Three-Bladed, Constant Speed, Full Feathering

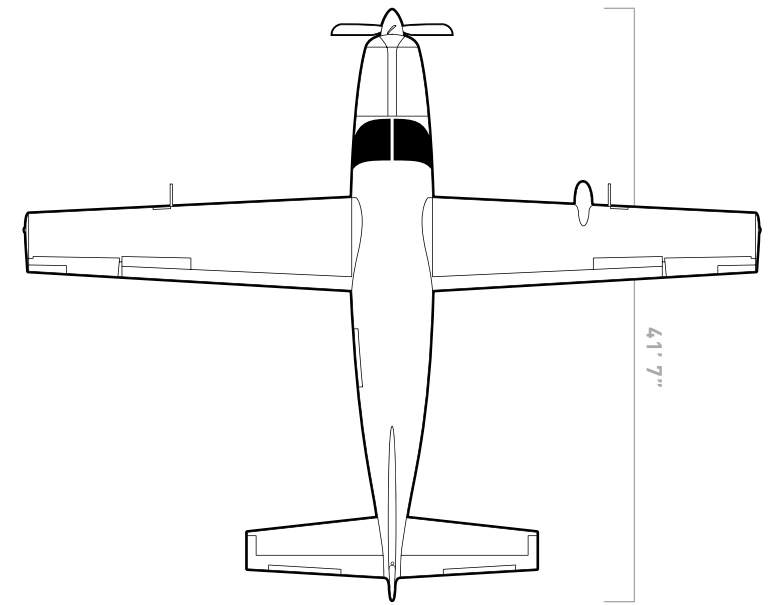

### RANGE AND PAYLOAD

**PAYLOAD** Super Cargomaster (with cargo pod)  
 (lb) BOW = 5,013 lb/2,274 kg  
 (kg) (Includes 200 lb pilot & 45 minute fuel reserve)

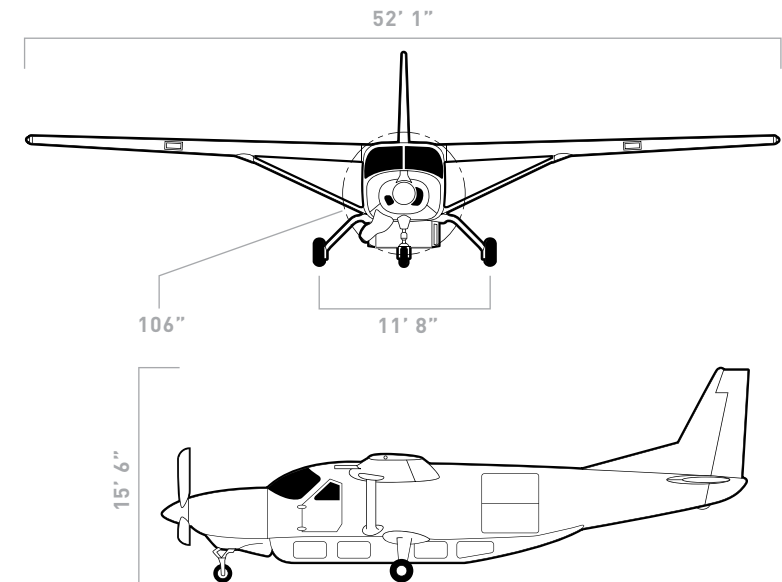
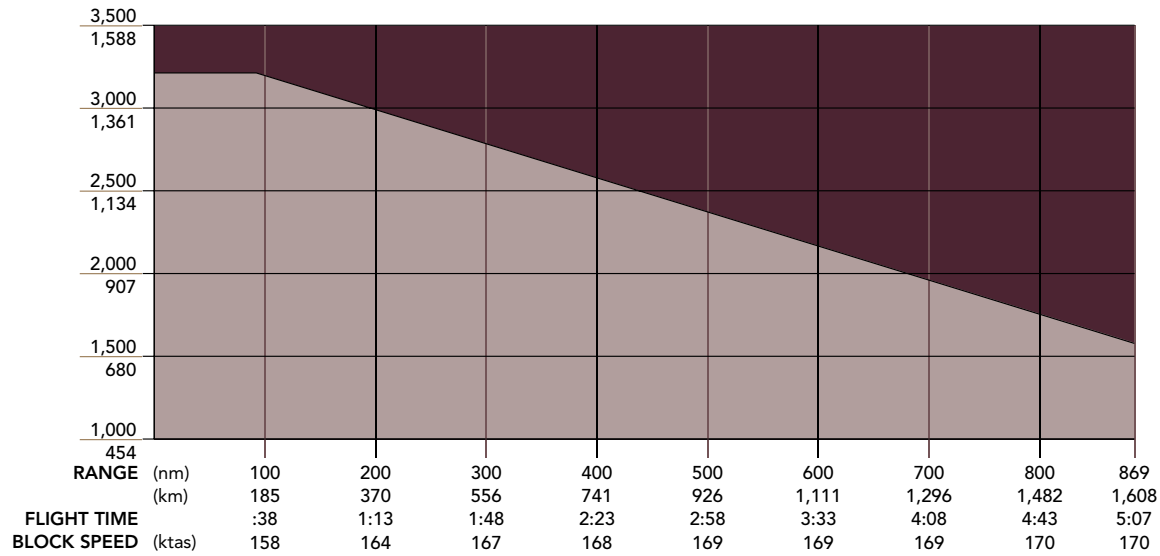



## A COMPANY WITH OPTIONS

We know that you sometimes need supplemental jet lift. CitationAir,™ wholly owned and controlled by Cessna Aircraft Company, provides transportation solutions for every customer need. A comprehensive product line consisting of Jet Cards, Jet Access, Jet Shares, Jet Management and Corporate Solutions allows for ultimate flexibility and simplicity through one single relationship.

CitationAir services the contiguous United States, southern Canada, Mexico, the Caribbean, the Bahamas and Bermuda.

With CitationAir, individuals and businesses have the opportunity to experience the safety, comfort, flexibility and privacy of private jet travel, supported by our Yellow Tie™ service, all backed by Cessna Aircraft Company.

### OUR AIRCRAFT

The CitationAir fleet includes the following Cessna aircraft:

Citation CJ3

Citation Excel and XLS

Citation Sovereign

Citation X\*

\*Currently only available for Jet Management customers.

CitationAir is flexible with adding additional Cessna Citation aircraft to our Jet Management fleet.



# A SUITE OF INNOVATIVE JET SOLUTIONS



At CitationAir, your aircraft will be a Cessna Citation. That's all we fly. Whatever your needs, we have efficient aircraft with outstanding short-field capabilities and the range to take you coast to coast nonstop.

## **CitationAir Jet Card**

The CitationAir Jet Card is the perfect combination of simplicity, flexibility and value. The first of its kind, this card offers significant savings 355 days per year, while still giving you 365-day access. With a fully refundable \$100,000 minimum purchase, you'll enjoy an unsurpassed experience on one of the industry's youngest fleet of business jets, the highest safety levels and innovative jet card pricing that provides savings unmatched in the industry.

## **CitationAir Jet Access**

Jet Access provides all the benefits of fractional ownership without the capital investment, asset valuation risk and remarketing fees associated with owning a share. Enjoy the ultimate flexibility to purchase additional hours as needed, re-size your annual hours commitment and change your aircraft type once a year.

## **CitationAir Jet Shares**

CitationAir's innovative fractional ownership program simplifies costs by incorporating all operating expenses into one annual or 12 monthly payments. Jet Shares differentiates the costs of flying on the slowest days versus the busiest days, allowing you the ability to choose your travel day option for additional savings. With Jet Shares, you are guaranteed the aircraft type purchased but have access to the entire fleet of aircraft. Upgrades and downgrades are available upon request and are subject to availability.



### **CitationAir Jet Management**

The Jet Management program provides all of the benefits of owning a Cessna Citation whole aircraft with none of the usual management and maintenance responsibilities, relieving customers of the burdens associated with owning and maintaining an aircraft. By placing an aircraft into the fleet, CitationAir is able to charter the aircraft to its customers, creating a revenue stream for Jet Management aircraft owners that will significantly defray their costs.



### **CitationAir Corporate Solutions**

The Supplemental Lift program gives companies access to CitationAir's entire fleet of Cessna Citation aircraft without the financial commitment required by traditional programs. Enjoy the ability to pay as you fly.



Please contact CitationAir at 1-877-MY-CITATION (1-877-692-4828) or visit [CitationAir.com](http://CitationAir.com) for more information.



Cessna Aircraft Company

---

[cessna.com](http://cessna.com)

1.800.4.CESSNA

+1.316.517.6056